

PDF

WWW.RENATOGIUSSANI.IT

LOUDSPEAKERS



**An anthology
of articles on
loudspeakers
from the pages of the
Journal of the
Audio Engineering
Society
Vol. 1 — Vol. 25
(1953-1977)**

LOUDSPEAKERS VOLUME 2



**An anthology
of articles on
loudspeakers
from the pages of the
Journal of the
Audio Engineering
Society
Vol. 26–Vol. 31
(1978-1983)**

Simplified Loudspeaker Measurements at Low Frequencies*

RICHARD H. SMALL

School of Electrical Engineering, University of Sydney, Sydney, N.S.W., Australia

The effective free-field frequency response and harmonic distortion of a direct-radiator loudspeaker system can be measured at low frequencies without establishing free-field radiation conditions. The technique is based on measurement of the acoustical pressure within the system enclosure and is simple and inexpensive. It provides useful response measurements up to about 200 Hz, and harmonic distortion measurements up to about 100 Hz.

Editor's Note: An acoustic anechoic chamber for testing loudspeaker systems down to 20 Hz is a frighteningly expensive structure. Neither my University nor Mr. Small's University has such a facility and right now I am not convinced that the data from an anechoic chamber relates well enough to the home or auditorium environment to convince universities to invest scarce dollars in such facilities. Even more pertinent to most of the members of the AES is the fact that only a fortunate few have access to these chambers while the number wanting to measure loudspeaker systems must exceed several thousand.

The outdoor measurement technique so well described by Shearman [1] is adequate but I can testify from personal experience that wind, rain, (snow in Colorado) and motorized vehicle noise are sufficiently annoying that an alternate method is badly needed. This Mr. Small has provided and the elegant simplicity of his method commends it to your understanding and use.

I had the pleasure of presenting this paper to the 41st. AES Convention and the familiarity gained with this work leads to anticipation of your question "is the method accurate and valid?" In his modest way, Small under-

states (Sec. 5) the accuracy of the method. In some previous work, one of my students (Mark Swan) measured pressure in a vented box and on-axis frequency response outdoors to verify some computer solutions. We were not clever enough to appreciate the significance of the excellent agreement of box pressure with theory but we had proved that the basic assumptions made by Small are quite valid. Some of my students are presently doing the experimental work needed to give complete verification of Small's method. A Project Note should appear in a few months to present this verification. In the meantime, if you want to make a very simple and accurate measurement of your loudspeaker system's low frequency response or distortion, I advise you to measure first and ask questions later.

J. R. Ashley

I. INTRODUCTION: The measurement of loudspeaker system characteristics is customarily carried out under free-field radiation conditions so that it will reflect only the properties of the loudspeaker system and not those of the environment. However, it is often difficult to establish true free-field radiation conditions at low frequencies. Outdoor test facilities are notoriously difficult to establish and maintain [1], while large indoor anechoic chambers do not provide a true free field at very low frequencies and must be carefully calibrated.

The measurement method described in this paper is based on the fact that the low-frequency output of a small direct-radiator loudspeaker system is directly related to

* Presented May, 1971, at the 13th National Radio and Electronics Engineering Convention, Institution of Radio and Electronics Engineers Australia, Melbourne, and October 5, 1971, at the 41st Convention of the Audio Engineering Society, New York. Published in *Proc. IREE Australia*, vol. 32, pp. 299-304 (Aug. 1971), and republished here with the permission of the Institution.

the acoustic pressure within the system enclosure. This pressure is essentially unaffected by the system acoustic load, and is the same in a reverberant environment as in an anechoic environment.

II. BASIC THEORY

A direct-radiator loudspeaker system radiating into a hemispherical (2π steradian) free field is illustrated in Fig. 1. The steady-state rms pressure inside the enclosure is p_B , the total output volume velocity crossing the enclosure boundaries is U_0 , and the rms sound pressure at a distance r from the system is designated p_r .

If the enclosure has negligible absorption losses, it can be represented at very low frequencies by an acoustic compliance C_{AB} which is related to the internal volume of air V_B by [2, p.129]

$$C_{AB} = V_B / \rho_0 c^2 \quad (1)$$

where ρ_0 is the density of air (1.18 kg/m^3) and c is the velocity of sound in air (345 m/s). Fig. 2 presents the acoustical analogous circuit of such an enclosure (impedance analogy). From analysis of this circuit, the relationship between output volume velocity and internal pressure is

$$U_0 = p_B \omega C_{AB} \quad (2)$$

where ω is the steady-state radian frequency.

The relationship between p_r and U_0 for the radiation conditions of Fig. 1, regardless of the type of system or the number of enclosure apertures contributing to the total U_0 [3, p. 270], is

$$p_r = (\rho_0 / 2\pi r) \omega U_0 \quad (3)$$

and the radiated power is [2, p. 189]

$$P_A = (\rho_0 / 2\pi c) (\omega U_0)^2. \quad (4)$$

If the loudspeaker system is removed from the anechoic environment, the pressure p_B and the volume velocity U_0 do not change significantly. These quantities are not noticeably affected by the acoustical load [4, p. 489], provided the environment is not a high- Q acoustical resonator and is spacious compared to the enclosure volume. It should thus be possible to determine the basic low-frequency free-field response and power output of a direct-radiator loudspeaker system by measuring the enclosure pressure while the system is located in any reasonable environment and then using the relationships in Eqs. (1)–(4).

A signal representing output volume velocity is ob-

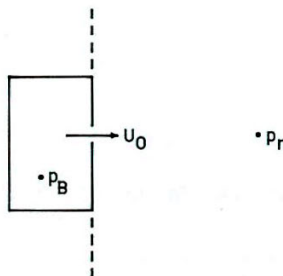

Fig. 1. Loudspeaker system radiating into hemispherical free field.

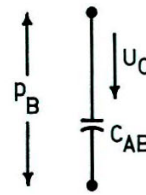

Fig. 2. Acoustical analogous circuit of lossless enclosure.

tained by multiplying the enclosure-pressure signal by a factor proportional to frequency as required by Eq. (2). This process must then be repeated to obtain a signal representing free-field sound pressure, as required by Eq. (3). An electronic differentiation circuit has exactly the desired property, i.e., a gain proportional to frequency, so two such circuits will perform the required operations. For calculation of radiated power, the pressure-measuring transducer must be calibrated, and the enclosure compliance and differentiation time constants must be known accurately. However, if only the relative frequency response is desired, calibration is not necessary.

III. EQUALIZATION

The preceding theory offers a simple means of obtaining the free-field response of a loudspeaker system having negligible enclosure losses, but only for very low frequencies. In particular, Eq. (1) is valid, i.e., C_{AB} is a constant, only for frequencies low enough that the wavelength of sound is greater than eight times the smallest dimension of the enclosure [2, p. 217]. This is a frequency limit of about 50 Hz for a moderate size enclosure.

Unfortunately, this is not a sufficient bandwidth for the study of loudspeaker systems. The response of many systems has not yet leveled off at this frequency, and to adequately observe the complete cutoff behavior of the system it is necessary to obtain a bandwidth of about 200 Hz. This can be done with quite reasonable accuracy by equalizing the factors that tend to contribute errors at higher frequencies.

Compliance Shift

At very low frequencies, all air in the enclosure is compressed equally and Eq. (1) is valid. At higher frequencies, the compression is no longer uniform and the effective compliance is reduced. The major factor in this compliance reduction is the air-load mass on the rear of the driver diaphragm which moves with the diaphragm at high frequencies without compression. The magnitude of this effect depends on the effective volume of the air-load mass compared to the enclosure volume; it is negligible for a small driver in a large enclosure but can amount to several dB error for a large driver in a small enclosure. The volume occupied by the air-load mass is typically $2.2a^3$, where a is the effective radius of the diaphragm [2, p. 217].

The compliance shift can be equalized by passing the enclosure-pressure signal through a shelf attenuator having an attenuation at high frequencies corresponding to the reduction of compliance. The attenuation must be fully effective at the frequency at which the rear air-load mass resonates with the enclosure compliance. This frequency depends somewhat on the shape of the enclosure

but is generally about $100(a/V_B)^{1/2}$ Hz, where a is in meters and V_B is in cubic meters. Good experimental results were obtained by centering the shelf equalizer at one third this frequency, but no rigorous theoretical justification for this location has been established.

Enclosure Losses

The presence of enclosure absorption losses means that the enclosure cannot be represented by a pure compliance but must be represented instead by a series compliance and resistance as shown in Fig. 3. R_{AB} is the series acoustic resistance due to the enclosure losses.

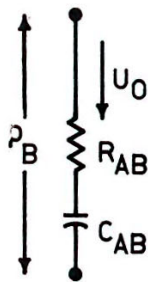

Fig. 3. Acoustical analogous circuit of enclosure with absorption losses.

If the value of R_{AB} is assumed to be independent of frequency, the relationship between enclosure pressure and volume velocity becomes

$$U_0 = p_B \left| \frac{j\omega C_{AB}}{1 + j\omega C_{AB} R_{AB}} \right|. \quad (5)$$

The presence of R_{AB} may then be equalized by placing a resistor of suitable value in series with the input capacitor of the differentiation circuit used to implement Eq. (2). The correct value of resistance can be determined from measurement of the system voice-coil impedance and subsequent calculation of the enclosure losses. The measurement method is given in the Appendix.

Even where the enclosure losses are very low, it is advisable to keep a minimum-value resistor in series with both differentiating capacitors to limit the differentiating bandwidth to about 1 kHz. This prevents excessive buildup of noise at high frequencies from interfering with the desired sound-pressure signal.

Pressure Uniformity and Standing Waves

At frequencies above about 50 Hz but still low enough for the wavelength to be longer than the enclosure dimensions, the pressure in the enclosure becomes noticeably nonuniform. The region nearest the driver is below average pressure, while the region farthest from the driver is above average pressure [2, pp. 32-33]. This condition increases in severity as the wavelength approaches the dimensions of the enclosure, but its effects can be tempered by careful placement of the pressure-sensing transducer. The best transducer location must be found by trial and error; it is often near the geometrical center of the enclosure volume. Above about 200-250 Hz, the magnitude and gradient of pressure changes and the development of standing waves within the enclosure render the method useless.

TABLE I. Loudspeaker System Data.

	Closed-box System	Vented-box System
Physical Data		
Enclosure volume, l	28	38
Driver diameter, m	0.25	0.35
Diaphragm radius, m	0.10	0.14
Small-Signal Parameters		
Driver resonance, Hz	25	25
Closed-box resonance, Hz	61	60
Vented-box resonance, Hz	—	45
Compliance ratio	5.3	5.1
System Q	1.65 at 61 Hz	0.22 at 25 Hz
Enclosure Q	15 at 61 Hz	12 at 45 Hz

IV. APPLICATIONS

Where a calibrated pressure transducer is available, it should be possible to test and calibrate sound sources and testing chambers below about 50 Hz. With careful equalization, the frequency response of small direct-radiator loudspeaker systems can be measured up to about 200 Hz.

The harmonic distortion of a loudspeaker system may also be measured if all major Fourier components of the signal representing sound pressure fall within the frequency range for which the response measurement is valid. This would usually include fundamental frequencies up to 50 Hz, with useful results often available up to 100 Hz.

An ideal transducer for measuring enclosure pressure is a condenser microphone with FET preamplifier. This type of transducer has a pressure response which is flat down to about 2 Hz, and high-quality models are usually supplied with calibration curves.

A tweeter loudspeaker driver having a closed back and high resonant frequency (above 1 kHz) may also be used as a sensing transducer. At low frequencies the output voltage of this transducer is proportional to the rate of change of pressure within the enclosure, i.e., this transducer already includes one of the required differentiation operations and thus operates with simpler circuitry. Unfortunately, the high- Q mechanical resonance usually present in this type of transducer makes distortion measurement difficult due to the unavoidable resonant-frequency component in the output which is accentuated by differentiation.

A typical test setup for the measurement of response and harmonic distortion, including equalization networks, is shown schematically in Fig. 4. If a tweeter is used as the transducer, the second differentiation stage is omitted.

The simplicity of the measurement technique suggests its usefulness for design as well as evaluation. It is particularly well suited to the final adjustment of a loudspeaker system designed in accordance with approximate analytical methods because the measured response includes the effects of all system losses and any frequency dependence of the system component values with the exception of enclosure resistance. This application is analogous to the use of familiar sweep alignment techniques in making final adjustments to the response of theoretically designed electrical filters or tuned amplifiers.

V. EXPERIMENTAL MEASUREMENTS

Two loudspeaker systems, one closed-box type and one vented-box type, were selected to illustrate the measurement technique. The low-frequency small-signal parameters of each system, calculated from voice-coil impedance measurements [4], are presented in Table I. These param-

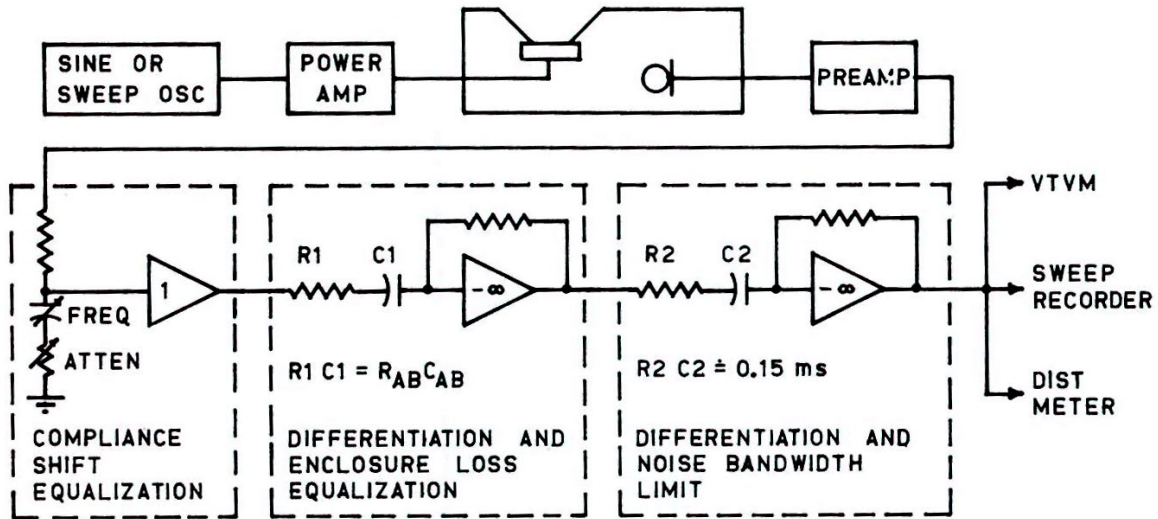

Fig. 4. Test setup for simulated free-field measurements at low frequencies.

ters were used to compute the expected system response and to determine the required enclosure-loss equalization (see Appendix).

Fig. 5 presents the computed response of the closed-box system, together with the response measured with a condenser microphone placed inside the enclosure at a location where pressure variations were least troublesome. The agreement between the two response curves is quite good up to about 180 Hz, in fact better than might be expected considering the assumptions and approximations involved in both methods. Distortion curves for the closed-box system, obtained using the same experimental setup, appear in Fig. 6. The distortion maxima just below the system resonant frequency reflect the large diaphragm displacement of this substantially underdamped system.

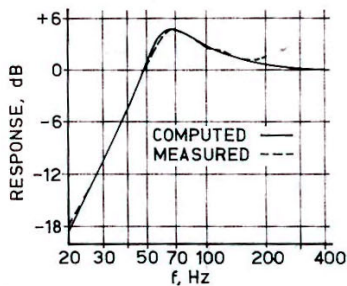

Fig. 5. Frequency response of closed-box system.

Fig. 7 presents the computed response of the vented-box system, together with the response obtained with the microphone in the enclosure. The agreement is again quite good, in this case up to about 250 Hz. Distortion curves for the vented-box system appear in Fig. 8. These are typical of a well-designed vented-box system, rising at frequencies below the vent-enclosure resonance.

The experimental results could not be checked in a true anechoic environment, but attempts to obtain the near-field response in a reverberant environment indicated that the response derived from enclosure pressure is in

both cases likely to be more accurate than the response computed from the measured parameters.

Fig. 9 illustrates the application of the technique to final adjustment of a loudspeaker system. The frequency response of a vented-box system initially designed according to theory [4] is plotted for several conditions of enclosure tuning. The duct length for the vent which gives the flattest response (125 mm) is clearly indicated by these measurements which were made using a tweeter as a sensing transducer. The initial design value of the duct length was 150 mm. The sag in the response with this vent is attributable to a slightly excessive amount of damping in the driver compared to that theoretically required, and to the contribution of enclosure losses not taken into account in the initial design calculations.

VI. CONCLUSION

The measurement technique described is a useful means of obtaining the low-frequency response and distortion characteristics of small direct-radiator loudspeaker systems for design or evaluation purposes. It is simple and inexpensive compared with established free-field techniques.

The theoretical accuracy of the technique at very low frequencies is worth investigation as a means of testing and calibrating sound sources, anechoic chambers, and reverberant rooms.

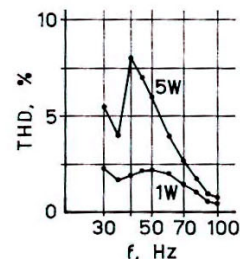

Fig. 6. Measured total harmonic distortion of closed-box system.

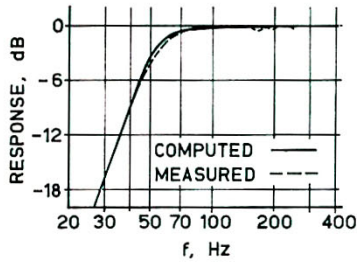

Fig. 7. Frequency response of vented-box system.

At higher frequencies, the equalization methods require further study, and accuracy of the technique should be checked by comparison with true free-field measurements.

APPENDIX—

APPROXIMATE MEASUREMENT OF ENCLOSURE ABSORPTION LOSSES

Absorption losses are only one type of loss that can occur in loudspeaker enclosures. It is difficult to separate the various kinds of losses but relatively easy to obtain an indication of total losses. In some cases, absorption losses are dominant and the measured total losses are then an adequate indication of absorption losses.

Absorption losses may be considered dominant in closed-box systems which are completely filled with damping materials and free of significant enclosure leaks. They are rarely dominant in vented-box systems unless the enclosure contains damping materials which either extend well out from the walls or are hung across the center of the enclosure as curtains. In these cases the total-loss measurement methods given below may be used to evaluate the absorption losses for equalization purposes. In all other cases, R_{AB} will probably be too small to require equalization, and the other losses present will be accurately represented in the response measurement by their direct effects on the total system volume velocity.

The loss measurements require the identification of frequencies at which the voice-coil impedance of the loudspeaker system has a maximum or minimum magnitude. In most cases, the impedance phase is zero at these frequencies and the frequencies may thus be identified more quickly and accurately by measurement of phase. However, if zero phase does not occur very close to the magnitude maxima or minima, then the frequencies of the latter should be measured as carefully as possible and used in the calculations.

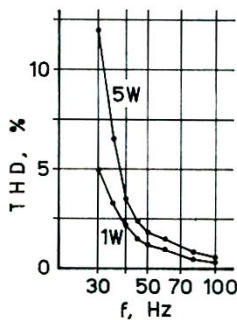

Fig. 8. Measured total harmonic distortion of vented-box system.

Closed-Box System

Measure carefully the dc resistance R_B of the driver voice coil and then the voice-coil impedance magnitude as a function of frequency; first with the driver in air, then with the driver in the enclosure. For the driver in air, find the frequency f_s for which the voice-coil impedance magnitude is a maximum. The ratio of this maximum impedance magnitude to the dc voice-coil resistance is defined as r_0 . Next find the two frequencies $f_1 < f_s$ and $f_2 > f_s$ for which the impedance magnitude is $R_E \sqrt{r_0}$. Then calculate [4, eq. (97)]

$$Q_{MS} = \frac{f_s \sqrt{r_0}}{(f_2 - f_1)} \quad (6)$$

and [4, eq. (95)]

$$Q_{ES} = \frac{Q_{MS}}{r_0 - 1} \quad (7)$$

Similarly for the driver in the enclosure, find the frequency f_C for which the voice-coil impedance magnitude is a maximum, and let the ratio of maximum impedance magnitude to dc resistance be r_{0C} . Find the two frequencies f_{1C} and f_{2C} as above and calculate

$$Q_{MC} = \frac{f_C \sqrt{r_{0C}}}{(f_{2C} - f_{1C})} \quad (8)$$

and

$$Q_{EC} = \frac{Q_{MC}}{r_{0C} - 1} \quad (9)$$

If the driver mechanical resistance is independent of frequency, the contribution of this resistance to Q_{MC} , labeled $Q_{MC(S)}$, is simply

$$Q_{MC(S)} = Q_{MS} \frac{f_C}{f_s} \quad (10)$$

This would be the value of Q_{MC} if there were no enclosure losses.

Now if Q_B is defined as the ratio of reactance to resistance for the enclosure at f_C , i.e.,

$$Q_B = 1/(2\pi f_C C_{AB} R_{AB}) \quad (11)$$

then the measured value of Q_{MC} will be such that

$$1/Q_{MC} = 1/Q_{MC(S)} + (1/Q_B)(C_{AT}/C_{AB}) \quad (12)$$

where C_{AT} is the total compliance of the system, i.e., enclosure and driver suspension acting together. If C_{AS} is the compliance of the driver suspension, then

$$1/C_{AT} = 1/C_{AS} + 1/C_{AB} \quad (13)$$

and it can be shown that [4, eq. (101)]

$$C_{AT}/C_{AB} = 1 - (f_s Q_{ES}/f_C Q_{EC}) \quad (14)$$

Combining Eqs. (10), (12), and (14),

$$Q_B = \left[1 - \frac{f_s Q_{ES}}{f_C Q_{EC}} \right] \frac{f_C Q_{MC} Q_{MS}}{f_C Q_{MS} - f_s Q_{MC}} \quad (15)$$

The value of Q_B is thus calculated from the above measurements and used to determine the equalization circuit time constant from Eq. (11):

$$C_{AB} R_{AB} = 1/(2\pi f_C Q_B) \quad (16)$$

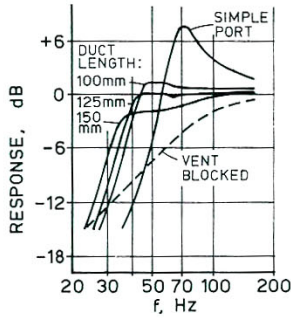

Fig. 9. Frequency response of vented-box system for various conditions of enclosure tuning.

Vented-Box System

Measure R_E and the driver voice-coil impedance magnitude as a function of frequency with the driver in air as above and find f_S , r_0 , Q_{MS} , and Q_{ES} .

With the driver mounted in the vented enclosure, again measure the voice-coil impedance magnitude as a function of frequency. Find f_L , the lowest frequency for which the impedance magnitude is maximum, f_H , the next higher frequency of maximum impedance magnitude, and f_M , the frequency between f_L and f_H for which the impedance magnitude is a minimum. The ratio of the minimum impedance magnitude at f_M to the dc voice-coil resistance R_E is defined as r_M . Now calculate [4, eq. (106)]

$$\alpha = \frac{(f_H + f_M)(f_H - f_M)(f_M + f_L)(f_M - f_L)}{f_H^2 f_L^2} \quad (17)$$

Then, to a sufficient approximation [4, eq. (107)],

$$Q_B = \frac{1}{\alpha Q_{ES}} \cdot \frac{f_M}{f_S} \cdot \frac{1}{r_M - 1} \quad (18)$$

where Q_B is the ratio of reactance to resistance for the

enclosure at f_M . Then, as in the closed-box case, the required equalization time constant is

$$C_{AB} R_{AB} = 1 / (2\pi f_M Q_B) \quad (19)$$

ACKNOWLEDGMENT

The basic idea for the measurement technique described here was suggested some years ago by A. N. Thiele, who also suggested the simple alternative of using a tweeter as the pressure transducer.

The experimental verification of the technique and study of equalization methods was carried out at the School of Electrical Engineering of the University of Sydney, as part of a program of postgraduate study into the low-frequency behavior of direct-radiator electrodynamic loudspeaker systems. Financial support for this program from the Australian Commonwealth Department of Education and Science is gratefully acknowledged.

The author wishes to thank Prof. J. R. Ashley for his generous cooperation in presenting this paper to the 41st Convention of the Audio Engineering Society and the Institution of Radio and Electronics Engineers Australia for granting permission for both representation and republication of this paper through the Audio Engineering Society.

REFERENCES

- [1] I. H. Shearman, "Assessment of Loudspeaker Quality," *Proc. IREE (Australia)*, vol. 31, p. 165 (June 1970).
- [2] L. L. Beranek, *Acoustics* (McGraw-Hill, New York, 1954).
- [3] J. E. Benson, "Theory and Design of Loudspeaker Enclosures," *Proc. IREE (Australia)*, vol. 30, p. 261 (Sept. 1969).
- [4] A. N. Thiele, "Loudspeakers in Vented Boxes," *Proc. IREE (Australia)*, vol. 22, p. 487 (Aug. 1961); also *J. Audio Eng. Soc.*, vol. 19, pp. 382-392 (May 1971) and pp. 471-483 (June 1971).

THE AUTHOR

Richard H. Small was born in San Diego, California in 1935. He received a BS from California Institute of Technology in 1956, and an MSEE from Massachusetts Institute of Technology in 1958. Following this, for six years (1958 to 1964) he was engaged in electronic circuit design for high-resolution mass spectrometers and other analytical instruments at the Research Center of Consolidated Electrodynamics Corporation, a subsidiary of Bell & Howell Company.

During 1962, Mr. Small visited Norway as an OEEC Growing Points Fellow, and worked on the design of control circuits for semiautomatic machine tools at Norwegian Technical University. In 1964 he was em-

ployed in electronic and mechanical design for the Industrial Division of World Design Center, Tokyo.

Since moving to Australia in 1965, Mr. Small has worked as a Teaching Fellow in the School of Electrical Engineering, University of Sydney, and as a private consultant. He is presently a Commonwealth Postgraduate Research Student in the School of Electrical Engineering, University of Sydney, researching the field of direct-radiator electrodynamic loudspeaker systems.

Mr. Small is a member of the Audio Engineering Society, the Institute of Electrical and Electronics Engineers, and the Institution of Radio and Electronics Engineers, Australia.

www.renatogiussani.it